

WOXCON

18Gbps HDMI™ Extender (70m) with PoC



CE-EX70-H2

User Manual

VER 2.0

Thank you for purchasing this product

For optimum performance and safety, please read these instructions carefully before connecting, operating or adjusting this product. Please keep this manual for future reference.

Surge protection device recommended

This product contains sensitive electrical components that may be damaged by electrical spikes, surges, electric shock, lighting strikes, etc. Use of surge protection systems is highly recommended in order to protect and extend the life of your equipment.

Caution

The product requires the use of UTP connectors. Please connect in direct interconnection method and do not cross connect.

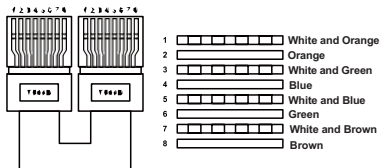

Direct Interconnection Method

Table of Contents

1. Introduction.....	1
2. Features.....	1
3. Package Contents.....	2
4. Specifications.....	2
5. Operation Controls and Functions.....	4
5.1 Transmitter Panel.....	4
5.2 Receiver Panel.....	5
5.3 IR Pin Definition.....	7
6. Application Example.....	8

1. Introduction

This 18Gbps HDMI Extender can extend HDMI HD signal and IR control signal to a distance up to 230ft / 70m via a single CAT6/6a cable, which can achieve zero-delay, uncompressed long-distance transmission between the transmitter and receiver. Video resolution is up to 4K2K@60Hz. It supports EDID copy pass-through function between the source device and display device. It supports PoC function.

This Extender can be widely used in multi-media conference halls, TV teaching and large-screen displays.

2. Features

- ☆ HDCP 2.2 compliant
- ☆ Support 18Gbps video bandwidth
- ☆ Support video resolution up to 4K2K@60Hz RGB/YCBCR 4:4:4, as specified in HDMI 2.0b
- ☆ The transmission distance can be extended up to 230ft / 70m via a single CAT6/6a cable
- ☆ Support HDR, HDR10, HDR10+, Dolby Vision, HLG
- ☆ Support bi-directional IR control signal pass-through
- ☆ Audio formats: LPCM 7.1, Dolby True HD, DTS HD Master
- ☆ EDID copy pass-through function between the source device and display device
- ☆ Support ARC and audio de-embedding, audio is output through the optical fiber port of the receiver
- ☆ Support bi-directional PoC (Power over Cable) function
- ☆ Compact design for easy and flexible installation

3. Package Contents

- ① 1 x 18Gbps HDMI Extender (Transmitter)
- ② 1 x 18Gbps HDMI Extender (Receiver)
- ③ 1 x IR Blaster cable (1.5 meters)
- ④ 1 x IR Wideband Receiver cable (1.5 meters)
- ⑤ 4 x Mounting Ears
- ⑥ 8 x Machine Screws (KM3*4)
- ⑦ 1 x 12V/1A Locking Power Adapter
- ⑧ 1x User Manual

4. Specifications

Technical	
HDMI Compliance	HDMI 2.0b
HDCP Compliance	HDCP 2.2
Video Bandwidth	18Gbps
Video Resolution	Up to 4K2K@60Hz RGB/YCBCR 4:4:4
IR Level	5Vp-p
IR Frequency	Wideband 20K-60KHz
Transmission Distance	4K2K@60Hz 4:4:4--70m, 1080P--70m (CAT6/6a cable)
Color Space	RGB 4:4:4, YCbCr 4:4:4, YCbCr 4:2:2, YCbCr 4:2:0
Color Depth	8/10/12bit
HDR	HDR, HDR10, HDR10+, Dolby Vision, HLG
Audio Formats	HDMI: LPCM 7.1CH, Dolby True HD, DTS-HD Master Optical: Dolby 5.1, DTS 5.1, PCM 2.0
ESD Protection	IEC 61000-4-2: ±8kV (Air-gap discharge), ±4kV (Contact discharge)

Connection	
Transmitter	Input: 1× IN [HDMI Type A, 19-pin female] Output: 1× OUT [HDMI Type A, 19-pin female] 1× CAT OUT [RJ45] Control: 1× SERVICE [Micro-USB jack] 1× IR IN [3.5mm Stereo Mini-jack] 1× IR OUT [3.5mm Stereo Mini-jack]
Receiver	Input: 1× CAT IN [RJ45] Output: 1× OUT [HDMI Type A, 19-pin female] 1× TOSLINK Control: 1× SERVICE [Micro-USB jack] 1× IR IN [3.5mm Stereo Mini-jack] 1× IR OUT [3.5mm Stereo Mini-jack]
Mechanical	
Housing	Metal Enclosure
Color	Black
Dimensions	Transmitter / Receiver: 90mm (W)×68mm (D)×18mm (H)
Weight	Transmitter: 160g, Receiver: 155g
Power Supply	DC 12V/1A; Support bi-directional PoC function
Power Consumption	3.36 W (max)
Operating Temperature	0°C ~ 40°C / 32°F ~ 104°F
Storage Temperature	-20°C ~ 60°C / -4°F ~ 140°F
Operating Humidity	20%~80% (relative humidity, non-condensing)
Storage Humidity	10%~90% (relative humidity, non-condensing)

5. Operation Controls and Functions

5.1 Transmitter Panel

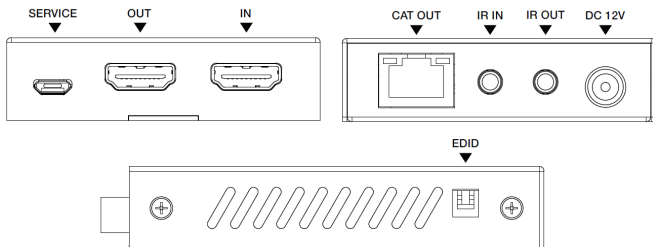

No.	Name	Function Description
1	SERVICE	Firmware update port.
2	OUT	HDMI signal loop output port. Connect to HDMI display devices with HDMI cable.
3	IN	HDMI signal input port. Connect to HDMI source device with HDMI cable.
4	CAT OUT	RJ45 connector for connecting the CAT IN port of the Receiver with CAT6/6a cable.
5	Link Signal Indicator (Green)	<ul style="list-style-type: none"> ▪ Illuminating: Transmitter and Receiver are in good connection status. ▪ Flashing: Transmitter and Receiver are in poor connection status. ▪ Dark: Transmitter and Receiver are not connected.
6	Data Signal Indicator (Orange)	<ul style="list-style-type: none"> ▪ Illuminating: HDMI signal with HDCP. ▪ Flashing: HDMI signal without HDCP. ▪ Dark: No HDMI signal.
7	IR IN	Connect to IR receiver cable, the IR receive signal will emit to the IR OUT port of the Receiver.
8	IR OUT	Connect to IR blaster cable, the IR emit signal is from the IR IN port of the Receiver.

No.	Name	Function Description
9	DC 12V	DC 12V/1A power input port. <i>Note that the extender supports POC function, it means that either Transmitter or Receiver is connected to 12V/1A power supply, the other doesn't need power supply.</i>
10	EDID DIP switch	Use the DIP switch to set EDID. (Switching to the upper end indicates 1; switching to the lower end indicates 0.) 11 - EDID information is copied from the display at the RX. 10 - EDID is preset to 4K@60Hz Stereo 01 - EDID is preset to 1080p Stereo 00 - EDID information is copied from the HDMI OUT at the TX.

5.2 Receiver Panel

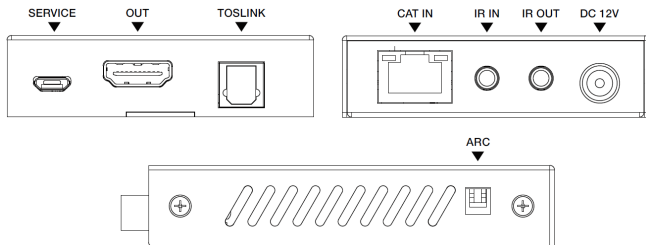

No.	Name	Function Description
1	SERVICE	Firmware update port.
2	OUT	HDMI signal output port. Connect to HDMI display devices with HDMI cable.
3	TOSLINK	Optical fiber audio output port. Connect to amplifier with optical cable.
4	CAT IN	RJ45 connector for connecting the CAT OUT port of the Transmitter with CAT6/6a cable.

No.	Name	Function Description
5	Link Signal Indicator (Green)	<ul style="list-style-type: none"> ▪ Illuminating: Transmitter and Receiver are in good connection status. ▪ Flashing: Transmitter and Receiver are in poor connection status. ▪ Dark: Transmitter and Receiver are not connected.
6	Data Signal Indicator (Orange)	<ul style="list-style-type: none"> ▪ Illuminating: HDMI signal with HDCP. ▪ Flashing: HDMI signal without HDCP. ▪ Dark: No HDMI signal.
7	IR IN	Connect to the IR receiver cable. The IR signal will send to the IR OUT port of the Transmitter.
8	IR OUT	Connect to the IR blaster cable, the IR signal is from IR IN port of the Transmitter.
9	DC 12V	DC 12V/1A power input port. <i>Note that the extender supports POC function, it means that either Transmitter or Receiver is connected to 12V/1A power supply, the other doesn't need power supply.</i>
10	ARC DIP switch	Use the DIP switch to control ARC function. (Switching to the upper end indicates 1; switching to the lower end indicates 0. Note that only the left switch is valid, the right switch is invalid.) 1X - Disable the ARC function 0X - Enable the ARC function

Note:

When the ARC function is enabled, the audio returned from the ARC supported TV connected to the Receiver will be output through the TOSLINK port (not the HDMI IN port or HDMI OUT port of the Transmitter);

When the ARC function is disabled, the audio extracted from the HDMI IN port of the Transmitter will be output through the TOSLINK port.

5.3 IR Pin Definition

IR Receiver and Blaster pin's definition is as below:



IR RECEIVER



IR BLASTER

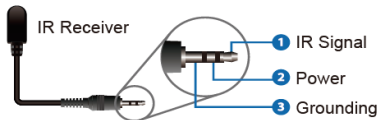
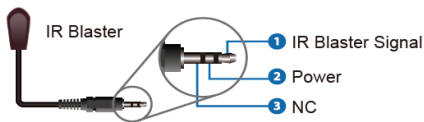

Note:

When the angle between the IR receiver and the remote control is $\pm 45^\circ$, the transmission distance is 0-5 meters;

When the angle between the IR receiver and the remote control is $\pm 90^\circ$, the transmission distance is 0-8 meters.

6. Application Example

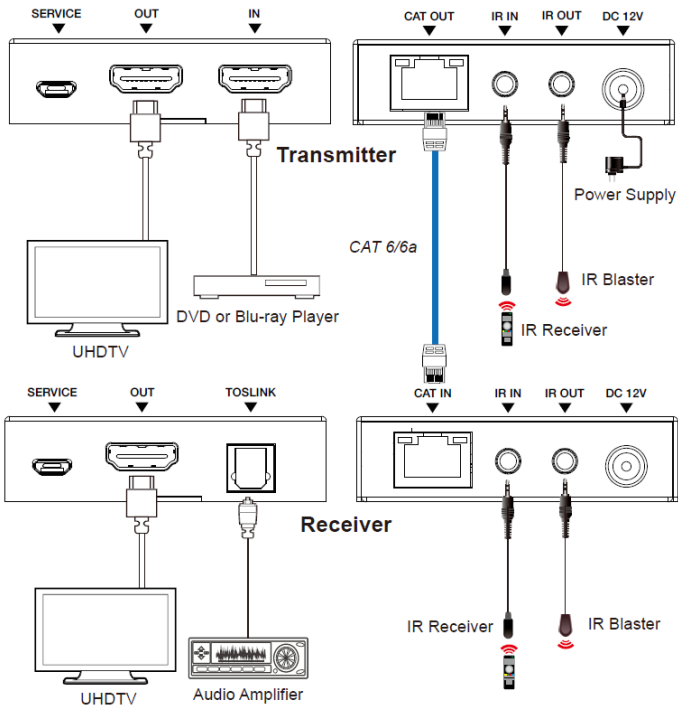

HDMI™
HIGH-DEFINITION MULTIMEDIA INTERFACE

The terms HDMI and HDMI High-Definition Multimedia interface, and the HDMI Logo are trademarks or registered trademarks of HDMI Licensing LLC in the United States and other countries.