

WOXCON



LGL173

17.3 inch LCD Monitor Motorized Lift

All Rights Reserved

Version: LGL173_2020V1.0

Introduction

Pop up LCD Monitor Lift is advance hiding all in one equipment designed for audio video system in office furniture. Monitor lift all in one system, HD Screen is supplier together. Monitor retractable vertically from desktop automatically. First monitor tilt angle is 0-25 degree, 0-60 degree adjustable titling angle to make prefect viewing angle for users. Virtually Silent working with excellent working life. Choose mute motor, through the CE certification; Strong stability, good vibration resistance. the noise is less than 35dbs, Up down device adopt double linear polished rod guide, smooth movements, no shaking, more durable. Monitor tilt device adopt gear mesh structure, make the monitor tilt degree more durable.

Features

- Automatic 25° inclination, 0-60° adjustable titling angle
- Support HDMI - VGA Switching
- Safety prevent clamping device
- HDCP compliant
- Support Individual monitor lift remote addressing
- Serial control & Remote Control to Lift operation

Dimensions

- Panel Size : 488.4*80mm
- First Cut Out Size : 472.5*70mm
- Second Cut Out Size : 489.5*81*3mm
- The LCD Box Size : 472.1*69*598mm
- Weight : 9.5 Kg

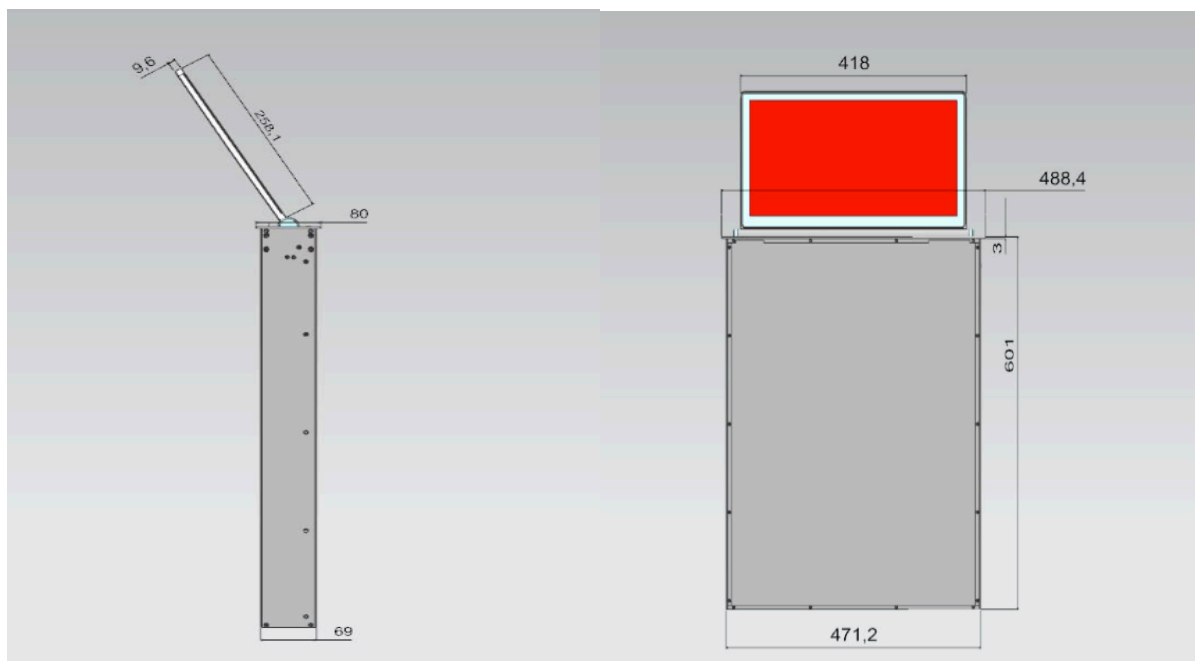

Control Way

- Touch key-press via buttons of front panel
- Remote Control
- RJ45 cable to connect to remote control
- RS485 Central Control

Panel Description

Brushed aluminum panel edging processing, high-grade utility for more conference table installation. Used chain transmission up-down.

1. This LCD monitor is provided with an automatic ON / OFF system. When the monitor is going up, the power will be switched ON automatically. In order to save energy and preserve the work life of the monitor, in the opposite state the monitor will be completely switched OFF
2. Control methods; Remote control RS485, central control, manual control
3. LCD Monitor Lift using the control panel button, weakness contacts remote control, RS485 code of centralized control combination, to adapt to various types of integrated system.
4. The panel 5 control button to complete the monitor up button, stop button, the monitor down button, HDMI-VGA switching button, monitor tilt button
5. Connector; HDMI – VGA, USB Type A for ON/OFF switching, USB Type B for Data, RJ45 connector for RS485
6. Slim Cabinet; Depth of the monitor is adjusted to the minimum for an aesthetic and modern solution.

Specifications

Monitor	
Size	17.3" IPS Monitor
Resolution	1920 (H) x 1080 (V)
Brightness	300 cd/m ²
Contrast Ratio	700:1
Viewing Angle	80/80/80/80 (Typ.)(CR>=10) (Left/ Right/ Up/Down)
Viewing Area	381.9 x 214.8 mm (HxV)
LED Backlight Lifespan	50.000 Hours
Materials	
Monitor Frame	Matt Silver Aluminum Alloy
Panel	Aluminum Alloy Brushed
Lift Box	Aluminum Alloy Brushed
General	
Input Signal	HDMI, VGA
USB Ports	USB Type A, USB Type B
Ethernet Port	RJ45 Cat5/6/7 (With Loop)
Control Port	RS485/RS232 Control the monitor
Work Temperature	-10~55℃
Relative Humidity	10%-90%
Power Supply	220V
Power Consumption	80W
Panel Size	488.4*80mm
First Cut Out Size	472.5*70mm
Second Cut Out Size	489*81*3mm
The LCD Box Size	472.1*69*598mm
Weight	9.5

Safety Precaution

- Do not dismantle the housing or modify the module to avoid electrical shock or burn.
- Using supplies not meeting the products' specifications may cause damage, deterioration or malfunction.

- Do not expose the unit to rain, moisture or install this product near water.
- Install the device in a place with fine ventilation.
- Do not use liquid or aerosol cleaners to clean this unit.
- Always unplug the power to the device before cleaning.
- Unplug the power when not used for a long period of time.
- Refer all servicing to qualified service personnel.

After-sales Service

We provide limited warranty for the product within two years.

Package Contents

17.3" Lift Monitor

Power Cable

Manuals

Applications

